

// New styles in smooth aluminium and for on-site infill



ET 500 door for collective garages

Robust, high-endurance door with numerous design possibilities







Infill variations	4-5
Detailed quality	6-7
Side door and wicket door	8
Space requirement	9
Size range	10-11
Operators	12-13
Accessories	14-15

ET 500 – quiet, smooth-running and maintenance-free

Optimum cost-effectiveness, long-term functional reliability as well as extremely quiet operation, even at high frequencies, are some of the striking features of the ET500.

The maintenance-free door construction opens and closes easily, quietly and safely with wear-free counter weight technology.

Number of parking spaces

Up to 50 parking spaces with the SupraMatic H operator.

Over 50 parking spaces with the ITO 400.

Advantages at a glance

- **Smooth, very quiet door travel**
- **Tested combination of door and door operator for low operator wear, a long service life, high operational safety and low operating costs**
- **Door construction designed for at least 250,000 door cycles**
- **Low required headroom, ideal for tight spaces. An optional subframe is available for fitting situations without lintel and sideroom.**
- **Galvanised, powder-coated door leaf in RAL 9006, other RAL colours on request**
- **Minimum swivelling out of door leaf**
- **Double cables and counter weight technology for safety, low wear, and permanent reliability of door action**
- **Synthetic rollers with ball bearing**
- **Also available with wicket door and side door**

Copyright:

No part of this brochure may be reproduced without our prior permission. We reserve the right to make changes without notification.

Some of the doors shown are special versions and may require approval in individual cases.



The complete, cost-effective solution with many design options

Infill variants



perforated steel sheet

Design 412, round
Design 413, rectangular

You can purchase the basic design with the best ventilation cross section in two versions, with round or rectangular notches.

Max. door width of 6000 mm



Smooth aluminium sheet

Design 420 // NEW

The infill with the smooth aluminium sheet inside the frame is available in a sheet thickness of 2 mm.

Max. door width of 6000 mm

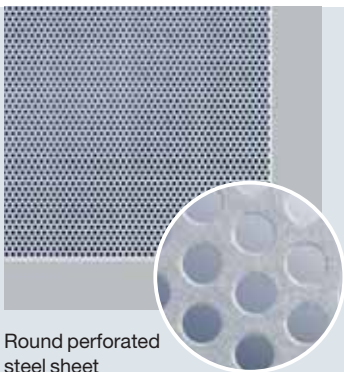

Round perforated steel sheet

Ventilation cross section:
45% of the infill surface

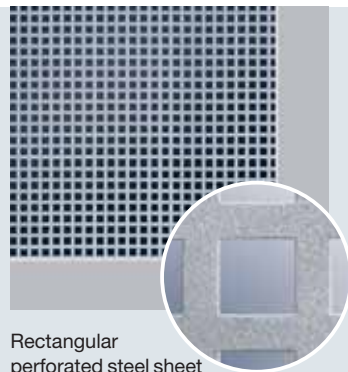

Rectangular perforated steel sheet

Ventilation cross section:
45% of the infill surface

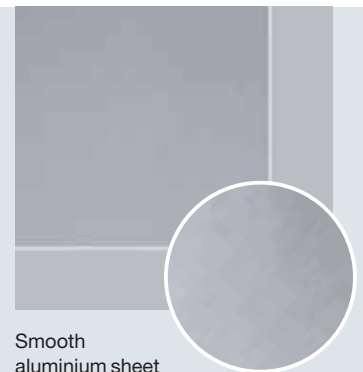

Smooth aluminium sheet



Flexibility in form and size. This not only applies to the door technology's variable dimensions and low space requirements, but also to numerous design possibilities.



Sections

Design 480

The variable section design (42 mm) matches Hörmann's sectional doors. It can be complemented by an aluminium frame with expanded mesh, perforated sheet or glazing infill.

Max. door width of 5000 mm



On site

Design 405, overlapping the frame Design 400, inside the frame // NEW

On-site infills offer endless individual design possibilities. This enables an optimum integration of the door in planned or existing facade designs. For maximum infill weight, see page 11.

Max. door width of 6000 mm



Section with ventilation grille

Ventilation cross section:
40 cm²/grille



Aluminium frame with expanded mesh

Ventilation cross section:
58% of the infill surface



Steel frame for on-site infill overlapping the frame

With vertical and horizontal reinforcement struts



Example for on-site infill inside the frame

With vertical struts



Convincing in detail



Small fitting dimensions

- Only 100 mm required headroom in combination with the SupraMatic H operator, only 120 mm required headroom in combination with the ITO 400 operator
- Only 140 mm sideroom needed for L version, 250 mm for S version

Low space requirements

- Minimum swivelling out of door leaf in front of the door opening (max. 200 mm), important for very tight spaces.

Robust construction

- Highly cost-effective thanks to long-lasting product quality
- Door construction designed for at least 250,000 door cycles
- Practically maintenance-free based on low-wear counter weight technology



**Selecting a Hörmann collective garage door is a decision for the future.
A decision for safety and low maintenance costs for years to come.**



Quiet door travel

- Door opens and closes quietly
- Precise roller guides in the track, no "wobbling" of the door leaf



Exemplary safety

- Double cables prevent the door leaf from falling
- Finger trap protection on the side and bottom edges through a safety gap between the door leaf and building structure
- Special EPDM bottom profile shape optimally seals the closing edge
- Prepared for closing edge safety device (required for use with the ITO 400 operator)



Perfect appearance

- Uniform appearance of frame profiles for outer frames, 80 mm; centre profiles, 60 mm
- Profile depth of only 60 mm
- Lateral safety gaps covered by a brush seal



Side door and wicket door for fast, convenient access



The wicket door

You can also obtain the ET500 with a wicket door on request

- Fitting is possible on the left, right or in the centre
- Clear passage width: 900 mm
- The clear passage height of the wicket door corresponds to the door leaf height of 160 mm.
- With overhead door closer as standard



The side door

On request, the ET500 is also available with a side door.

- Matching the respective design
- The clear passage width of 1500 mm is reduced if the opening angle is less than 180°.
- Clear passage height 2500 mm
- With lever/lever, prepared for profile cylinder, black plastic as standard



Maximum passage area with minimum fitting dimensions

Space requirements

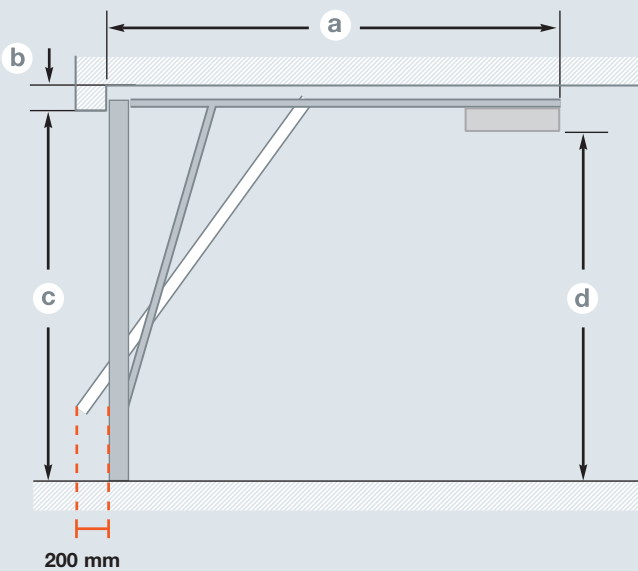

200 mm

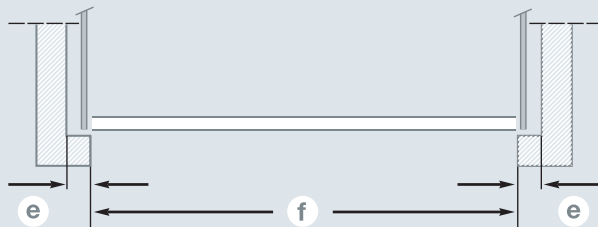

- (a) Overall length of SupraMatic H**
- | | | | |
|----------------------|--------------|-------------|---------|
| Opening height up to | 2125 mm | (C): K-rail | 3200 mm |
| Opening height | 2130-2300 mm | (C): M-rail | 3450 mm |
| Opening height | 2305-2500 mm | (C): L-rail | 4125 mm |
- ITO 400/ITO 400 FU** (C): K-rail 3840 mm
- (b) Required headroom* SupraMatic H**
- | | |
|---|--------|
| Doors with surface-mounted infill up to 20 mm | 100 mm |
| Doors with wicket doors | 120 mm |
| ITO 400/ITO 400 FU | 100 mm |
| Doors with surface-mounted infill up to 20 mm | 120 mm |
| Doors with wicket doors | 140 mm |
- (c) Clear opening height**
- | | |
|--|--------------|
| Ordering dimension height (BRH), ordering size | 2000-2500 mm |
|--|--------------|
- (d) Clear passage height**
- | | |
|-------------------------|-----------|
| Up to BRB 4500 mm | = BRH -20 |
| From BRB 4500 mm | = BRH -60 |
| Doors with wicket doors | = BRH -70 |
- (e) Lateral space requirement***
- | | |
|------------------------------|-----------------|
| ET500 L (light variant) | at least 140 mm |
| ET500 S (heavy-duty variant) | at least 250 mm |
- (f) Clear opening width**
- | | |
|---|--------------|
| Ordering dimension width (BRB), ordering size | 2250-6000 mm |
|---|--------------|

* An optional subframe is available for fitting situations without lintel and/or sideroom.



Safety in two design versions

Maximum size ranges*

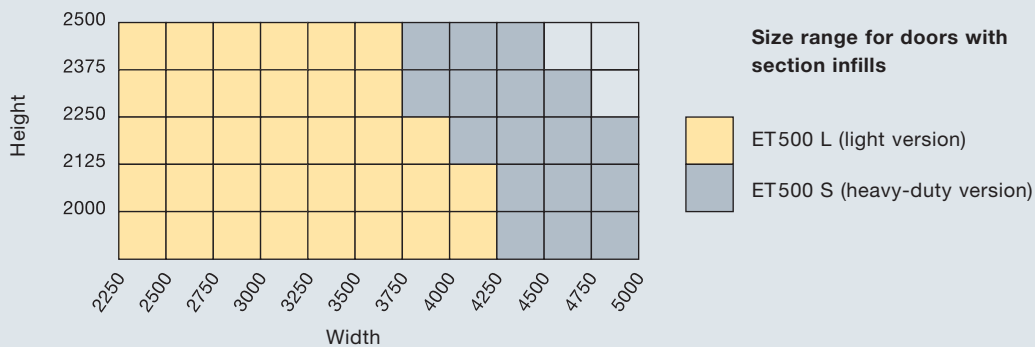
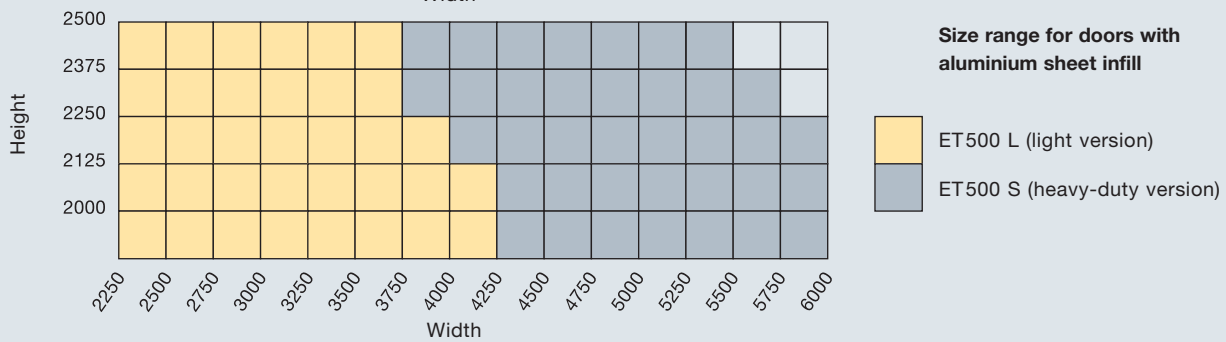
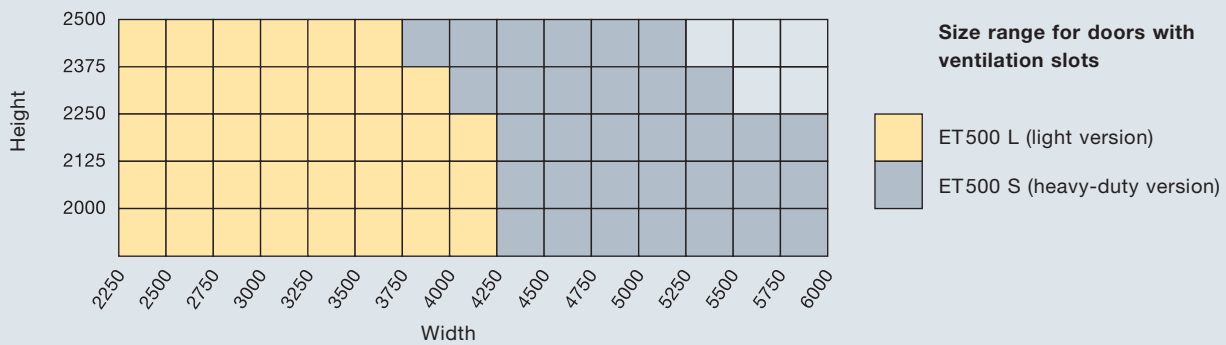



The technically mature and maintenance-free door construction provides you with a high degree of security and operating comfort.

Maximum size ranges*

Height	2500	14	12	10	10	8	6	6									
	2375	24	22	18	18	16	14	12	12	8	8	8	6	6			
	2250	14	12	12	10	8	8	6	6								
	2125	26	22	20	18	16	14	14	12	10	8	8	6	6	6		
	2000	16	14	12	10	10	8	8	6								
		28	24	22	20	18	16	14	14	10	10	8	8	6	6	6	
		18	16	14	12	10	10	8	6								
		30	26	24	20	18	18	16	14	10	10	10	8	8	6	6	
		18	16	14	12	10	10	8	6								
		32	28	24	22	20	18	18	16	12	10	10	8	8	8	6	
		2250	2500	2750	3000	3250	3500	3750	4000	4250	4500	4750	5000	5250	5500	5750	6000
		Width															

Size range for doors with on-site infill overlapping the frame
The numbers in the table indicate the maximum infill weight/m².

- Infill weight/m² for ET 500 L (light version)
- Infill weight/m² for ET 500 S (heavy-duty version)

Height	2500	14	12	12	10	8	8	6	6								
	2375	26	24	20	18	16	14	14	12	8	8	6	6	6			
	2250	16	14	12	10	8	8	8	6								
	2125	28	24	22	20	18	16	14	12	10	8	8	6	6	6		
	2000	18	14	14	12	10	8	8	6								
		30	26	24	22	18	18	16	14	10	10	8	8	6	6	6	
		18	16	14	12	10	10	8	8								
		32	28	26	24	20	18	18	16	12	10	10	8	8	6	6	
		20	18	16	14	12	10	10	8								
		34	32	28	26	22	20	18	16	12	12	10	10	8	8	6	
		2250	2500	2750	3000	3250	3500	3750	4000	4250	4500	4750	5000	5250	5500	5750	6000
		Width															

Size range for doors with on-site infill inside the frame
The numbers in the table indicate the maximum infill weight/m².

- Infill weight/m² for ET 500 L (light version)
- Infill weight/m² for ET 500 S (heavy-duty version)

* Note varying size and weight information for version with wicket door. Talk to your Hörmann partner.



Door operators for collective garages Comfortable, safe and compact



SupraMatic H garage door operator

The SupraMatic H is perfectly matched to the Hörmann ET 500 collective garage door.

It is especially recommended for collective garages in buildings with flats, hotels or office buildings.

Area of application

- **Number of parking spaces: up to 50**
- Pull and push force 1000 N, short-term peak load 1200 N
- Can be expanded through additional units (activating kit for warning light, traffic control)

Function and safety

- Emergency release from inside
- "Soft" start and "soft" stop for gentle and quiet door travel
- Integrated lighting with 2-minute light set at the factory
- Patented door locking in the operator boom
- Settings directly on operator via the operating panel
- Incl. photocell



Accessories and warning lights enable safe and comfortable passage for cars.

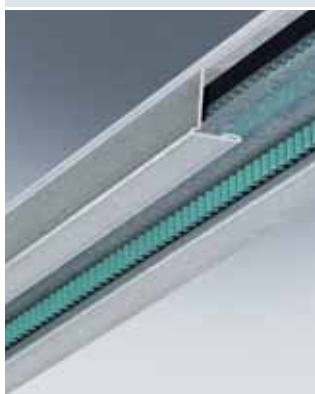

Toothed belt

Thanks to a toothed belt, the SupraMatic H is maintenance-free.

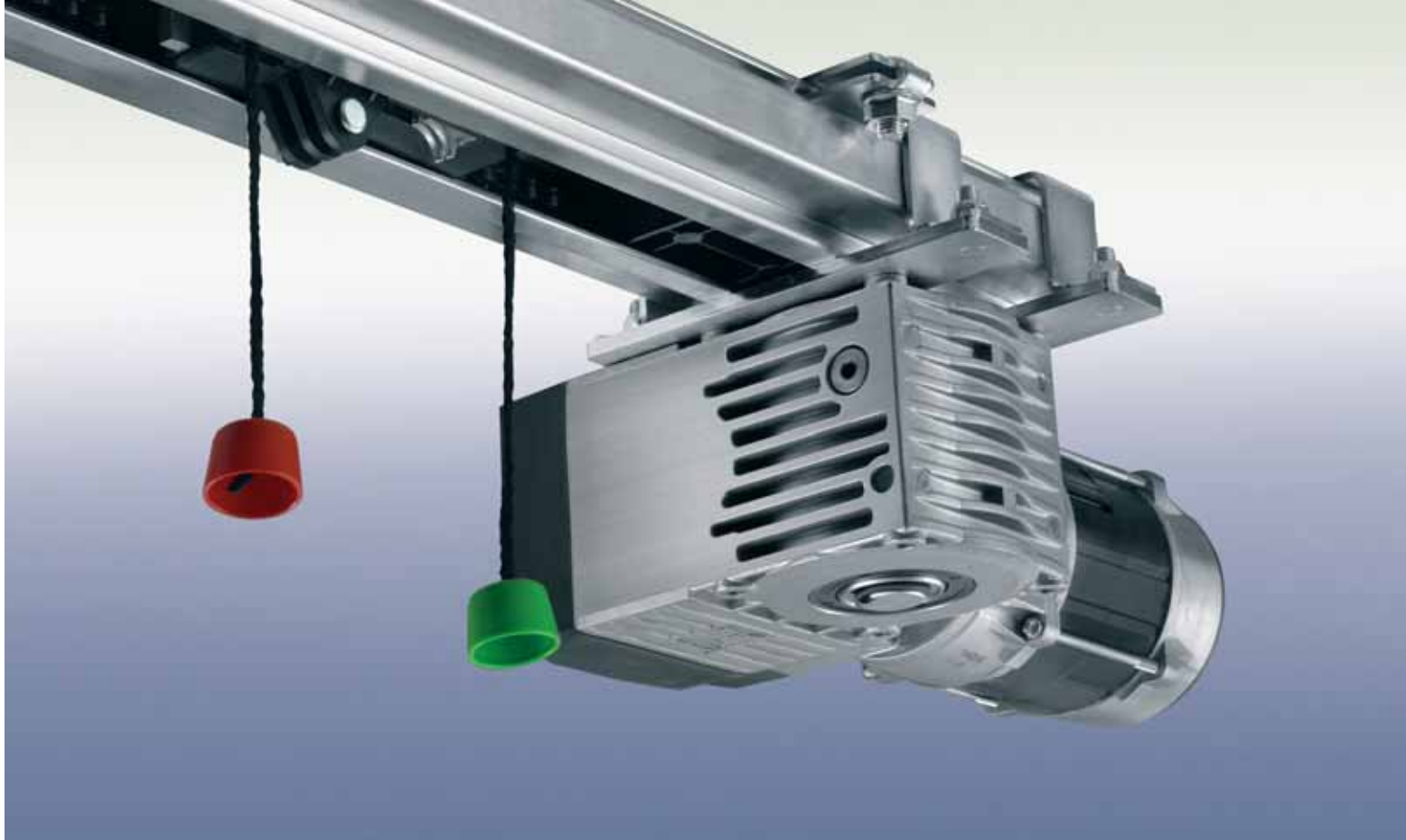

ITO 400/ITO 400 FU chain drive

The ITO 400 chain drive is equally suited for doors in high-traffic underground garages as well as in the commercial sector.

Area of application

- **Number of parking spaces: over 50**
- Can be combined with different controls (depending on requirements)
- Can be expanded through additional units (activating kit for warning light, traffic control)

Function and safety

- Soft start and stop for quiet and gentle door travel in the frequency converter version (FU).
- Emergency release via Bowden cable
- Operator and control are protected against hose-water (IP 65)
- Settings via control panel on a separate control
- Standard safety accessories for the ET500: roll-up safety device, door and side closing edge safety device, photocell



Traffic control in combination with warning lights ensures safe and reliable control of the driveway.

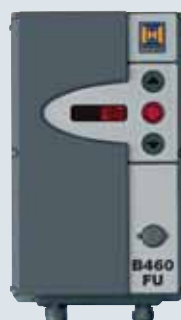

The control for the operator

Using the menu on the perfectly matching control for the ITO 400, you can set e.g. desired opening times and visual displays with warning lights quickly and easily.

We offer you an extensive range of accessories adjusted to your individual needs

Hand transmitter for impulse control, receiver



4-button mini hand transmitter HSM 4



2-button hand transmitter HSE 2



4-button hand transmitter HS 4



1-button hand transmitter HS 1



4-button hand transmitter HSP 4
with transmission block, for 4 functions



4-button security hand transmitter HSS 4
Additional function: copy protection for hand transmitter coding



Design hand transmitter HSD 2-A aluminium look
with transmission block, for 2 functions, can also be used as a keyring



Design hand transmitter HSD 2-C high-gloss chrome plating
transmission block, for 2 functions, can also be used as a keyring



Hand transmitter HSZ 2
for 2 functions, for insertion in vehicle cigarette lighter



Hand transmitter HSZ 1 // NEW
for one function, for insertion in vehicle cigarette lighter

1-channel receiver HEI 1
(not shown)
for one basic function, e.g. warning lights

2-channel receiver HEI 2
(not shown) e.g. necessary for traffic control

Code switch, finger-scan, transponder key switch



Code switch CTR 1b, CTR 3b
The code switches CTR 1b and CTR 3b with illuminated button panel provide high security to combat unauthorised entry. You simply enter your own personal combination code; a key is no longer needed. The deluxe version CTR 3b allows you to open a second door and switch on the outside lighting or operate a door in your choice of direction.



Radio code switch FCT 10b
The radio code switch FCT 10b offers the following additional functions in contrast to the code switches CTR 1b and CTR 3b: simple installation, since no cables need to be routed, with up to 10 radio codes (868.3 MHz) for actuating up to 10 doors.



Code switch CTV 1/CTV 3 // NEW
(not shown) with keypad protected against vandalism, same function as CTR 1b/CTR 3b.



Finger-scan FL 12, FL 100
A fingerprint allows you to open your garage door safely and easily. With a different finger, you can operate an additional garage door or the entrance gate, for example. You can purchase the finger-scan in two versions: the FL 12 for 12 storable fingerprints or FL 100 for 100 fingerprints.



Transponder switch TTR 100, TTR 1000
The comfortable way to open doors: you simply hold the transponder key with your own personal code for less than a second 2 cm in front of the reader. No contact needed! This is extremely practical at night. Suitable for max. 100 transponder keys (TTR 100) or 1000 transponder keys (TTR 1000). Two transponder keys are included on delivery.



Expansion kit for warning light ES 1
 In a separate housing, two relays for controlling warning lights, options relay (momentary impulse) for controlling lights, impulse input, reducible hold-open phase, emergency-off button can be connected, keypad for SupraMatic H and automatic timed closing (e.g. ZSU 2) can be switched off, incl. 2 warning lights (yellow).



Expansion kit for warning light ES 2
 Technically identical to ES 1. In addition, programming of the SupraMatic H can be performed via the expansion kit. Connection of a closing edge safety device, as well as a safety or through-traffic photocell, is possible. Connection of a closing edge safety device. Adjustable hold-open phase of 5 - 480 seconds, pre-warning time of 1 - 170 seconds, incl. 2 warning lights (yellow).



Expansion kit for traffic control EF 1
 Technically identical to ES 2, additional command impulse, entrance and exit, entrance function takes precedence, limit switch reporting via integral relay, incl. 2 traffic lights (red/green).

Activating kit for warning lights in separate additional housing or for installing in an existing housing, incl. 2 warning lights, yellow
 expansion kit for control A/B 445, A/B 460, B 460 FU.
 The activating kit for warning lights provides an optical display during door travel. Optionally available with weekly timer. Application options: approach warning (for A/B 445, A/B 460, B 460 FU), automatic timed closing (for A/B 460, B 460 FU). On expiration of the set hold-open phase (0-480 s), the warning lights blink for a set pre-warning period (0-70 s) and during the door cycle.

Traffic control in separate additional housing or for installing in an existing housing, incl. 2 traffic lights, red/green
 expansion kit for control A/B 460, B 460 FU.
 The activating kit for warning lights provides an optical display for traffic control. (Optional weekly timer).
 Length of green phase: adjustable between 0-480 s.
 Length of clearance phase: adjustable between 0-70 s.

Dimensions (W x H x D)

Warning light (yellow)	170 x 277 x 210 mm
Traffic light (red/green)	170 x 467 x 210 mm
Additional housing	195 x 160 x 128 mm

Key switch, key switch post, pull switch



STUP, STAP

Key switch
 Recessed or surface-mounted in two versions, each with 2 keys.

You can also find additional comfort and safety accessories in the brochure for garage door operators or ask your Hörmann specialist.



The illustration shows the version with integrated key switch STUP (as an accessory).

Key post STS 1
 With adapter for assembly TTR 100/1000, FL12/100, FCT 10b, CTR 1/3, CTV 1/3 or STUP. The command units must be ordered separately. The top and bottom end of the post come in RAL 7015 (slate grey). The upright pipe is stove-enamelled in RAL 9006 (white aluminium).
 Dimensions: 300 x 1250 mm (d x H)
 Protection category: IP 44



Pull switch ZT 2 with cable
 Impulse entry for opening and closing.
 Dimensions: 60 x 90 x 55 mm (W x H x D)
 Pull cord length: 3.2 m
 Protection category: IP 65

Hörmann: Quality without Compromise



Hörmann KG Amshausen



Hörmann KG Antriebstechnik



Hörmann KG Brandis



Hörmann KG Brockhagen



Hörmann KG Dissen



Hörmann KG Eckelhausen



Hörmann KG Freisen



Hörmann KG Ichtershausen



Hörmann KG Werne



Hörmann Genk NV, Belgium



Hörmann Beijing, China



Hörmann LLC, Montgomery IL, USA

Hörmann is the only manufacturer worldwide that offers you a complete range of all major building products from one source.

We manufacture in highly-specialized factories using the latest production technologies.

The close-meshed network of sales and service companies throughout Europe, and activities in the USA and China, make Hörmann your strong partner for first-class building products, offering "Quality without Compromise".

GARAGE DOORS

OPERATORS

INDUSTRIAL DOORS

LOADING EQUIPMENT

HINGED DOORS

DOOR FRAMES

Hörmann (UK) Ltd, Gee Road, Coalville, Leicestershire LE67 4JW
Phone (01530) 513000, Fax (01530) 513001



(issue 11.08) 85 651 E/P - 1.0 - Print 12.08

www.hoermann.com